

# A Rapid Emergency Deployment Mobile Communication Node

Ioannis G. Askoxylakis, Antonis Makrogiannakis, Andreas Miaoudakis, Stefanos Papadakis, Nikolaos E. Petroulakis,  
Manolis Surligas, Apostolos Traganitis and Nikolaos Vervelakis

Institute of Computer Science,

Foundation for Research and Technology-Hellas

Heraklion, Crete, Greece

{asko, makrog, miaoudak, stefpap, npetro, surligas, tragani, vervelak}@ics.forth.gr

**Abstract—** In an Emergency and/or Crisis Situations (ECS) like earthquakes, floods, tsunamis, fires, terrorist attacks etc. the adequate operation of communication services is of extreme importance. History has shown that poor communication in such cases resulted in several casualties. In ECS fixed communication infrastructure might be unserviceable due to sustained damages. Evermore, the communication demand is highly increased in such cases resulting in poor quality of service as both civilians and authorities are trying to establish communications. In this paper, a Rapid Emergency Deployment mobile Communication (REDComm) node is presented. REDComm nodes include wireless communication technologies, to provide various telecommunication services in ECS and interoperability between them. It incorporates an 802.11a mesh cognitive radio technology that operates in the television broadcasting frequency bands to provide a backbone networking with increased range and flexibility. REDComm is constructed upon a trailer chassis able to minimize setup time, which is valuable in ECS. The presented platform is powered by a hybrid power source that combines thermal, solar and wind energy and eliminates the need for external power supply.

**Keywords—**Emergency Communications; Disaster mitigation; Emergency and Crisis situations

## I. INTRODUCTION

In Emergency and Crisis Situations (ECS) several authorities like police, fire department, civil protection etc. are involved. The coordination and cooperation of every involved authority plays a crucial role not only for efficient ECS mitigation but also for the safety of the respective Rescue Teams (RTs). For example in the 9/11 terrorist attack at the World Trade Center, a police helicopter warning that the north tower was about to fall was not heard by firefighters resulting in several casualties [1]. In addition, the 911 operators were not well informed about the situation and did not advise callers to evaluate the towers [2]. Therefore, emergency management and disaster mitigation is highly affected by communication efficiency and interoperability [3] of the various communication systems that are used.

In ECS communication demands increase dramatically as the emergency response authorities require live information exchange between the command centers and the disaster scene, victims are seeking for guidance and assistance, and

citizens are trying to get informed about their families and friends. Therefore, communication is critical in emergency situations for successful disaster mitigation. In ECS existing communication infrastructures may have been damaged from the disaster and be unserviceable for hours or even days. Consequently, there is the need to augment and/or replace the damaged communication networks with rapid deployable ones that can be deployed near the disaster scene and connect with the existing ones. This way communication restoration can be achieved in minimum time, providing the essential services.

In this paper, a Rapid Emergency Deployment mobile Communication (REDComm) node is presented. REDComm is a trailer based communication node that utilizes several communication technologies in order to provide multiple communication services in ECS. Such services include not only Emergency Response Authorities (ERA) traditional communications, but also modern services to ERA such as live video streaming and multimedia content sharing as well as public addressing and victim communication. A REDComm node includes a hybrid power source based on both renewable and non-renewable energy generators and batteries to provide electric autonomy. A pneumatic telescopic mast is installed to support communication antennas providing mobility and increased coverage range.

One or more REDComm nodes can be easily and quickly deployed in any location of interest to provide communication services. The usage of mesh [4] networking architecture forms a redundant, seamless, self-healing, backbone network and that is able to route communication traffic dynamically over the most appropriate path and technology. Eight REDComm nodes have been designed and implemented by the Telecommunications and Networks Laboratory (TNL) at the Institute of Computer Science (ICS) of the Foundation for Research and Technology-Hellas (FORTH) and will be evaluated in drills and real-life situations with the Hellenic ERAs such as police, fire department the national emergency aid center and the Region of Crete that participate in the REDComm [5] project.

The rest of this paper is organized as follows. In section II the interoperability issues in emergency and crisis situations are addressed. A basic system description of the REDComm

node is presented in section III. In section IV typical usage scenarios of the system are discussed. Finally section V concludes the paper.

## II. INTEROPERABILITY IN EMERGENCY COMMUNICATIONS

At the early stages of ECS recovery RTs belonging to different ERAs arrive at the disaster scene. These teams usually start to operate independently to each other and later they become part of a centrally coordinated mitigation plan. Each RT communication is typically based on a Push To Talk (PTT) service. PTT is an old-fashioned half duplex voice service that uses a narrowband channel to transmit voice in a point to multipoint scheme. Every member of the team that carries a suitable PTT transceiver tuned in the RT predefined frequency can listen to the transmissions. PTT can offer instant contact and group talk to ERAs [6]. For the communication of the ERAs to their Coordination Centers (CCs), a repeater architecture is incorporated that is using a fixed frequency offset between transmit and receive path [7].

Unfortunately due to the old-fashioned analog technology used, there is no relay functionality among the nodes of these networks and thus coverage range is limited. Moreover, there is no interoperability between deferent ERA's networks as they use either different frequencies and/or different repeater schemes (different frequency offsets). Due to that fact, there is no way to have direct communication from a central coordination center to the involved RTs and usually such communication is relayed through each ERA's predefined coordination center, which affects central coordination efficiency.

Regarding interoperability, another issue is that a direct communication channel between civilians (especially those requiring immediate assistance) and responders does not exist. A victim has to use the mobile or fixed telephone network to contact the various ERA CC to seek for assistance. Then the CC will communicate the appropriate RT to transfer information about victim status and location to guide rescue. The lack of direct communication between victims and RTs affects rescue efficiency. For example, a trapped person of an earthquake could give guidance directly to the RT if he/she could talk directly to a RT member during the rescue.

## III. REDCOMM NODE DESCRIPTION

Each REDComm node utilizes a heterogeneous network architecture incorporating different wireless network technologies to support multiple types of services. The nodes are equipped with a powerful Linux-powered dual Intel Xeon workstation that controls all its functionality, and which operates as a heterogeneous network gateway to route IP and voice traffic. Remote control and monitoring of all node's functions is also possible. In Fig. 1 the first REDComm node prototype is shown. The main subsystems of the REDComm node are presented in the following section:

### A. Backbone Network interfaces

Each REDComm node is equipped with three Software Defined Radio (SDR) PCIe cards, which provide a robust and flexible transceiver hardware for the backbone connectivity that is difficult to be matched by any typical wireless interface.

The physical layer of IEEE 802.11a has been implemented entirely in software on the open source GNU Radio platform [8], and by proper custom modifications it is presented as a normal wireless interface to the Linux operating system. Therefore, there are three SDR-based 802.11a interfaces, which are used as the Backbone Network Infrastructure (BNI) for the REDComm node.



Fig. 1. Actual picture of the first REDComm node prototype with the pneumatic mast partially extended.

Each of the BNI interfaces although it is based on the IEEE 802.11a wireless network standard, instead of using the 5 GHz ISM bands, it operates on the 450 to 850 MHz frequency range. This range is used worldwide for terrestrial television broadcasting and is quite underutilized, especially in the areas where the transition to digital TV standards has been completed. These underutilized regions of the spectrum are called white spaces and by the use of Cognitive Radio (CR) techniques may be exploited for various uses by unlicensed, also known as secondary, users (SU) [9]. This frequency band was selected based on the much better propagation characteristics in comparison with the over-utilized 2.4 and 5 GHz ISM bands, providing a much higher coverage range especially in non-line of sight environments, i.e. a dense city

or forest. In the BNI mesh routing algorithms [10] are utilized to provide a redundant, robust, self-healing ubiquitous backbone network [11][12].

### B. Satellite Transceiver

The REDComm node is equipped with an auto-acquisition satellite antenna system, able to provide Internet access everywhere, when either the existing infrastructures have failed or the node is out of their range.

The satellite subsystem uses a motorized parabolic dish antenna, which is controlled by a custom hardware and software implementation. This equipment uses the orientation and position data from a digital compass and a Global Position System (GPS) device to perform an initial coarse alignment of the satellite dish to the appropriate satellite. Then an algorithm fine-tunes the alignment of the antenna maximizing the received signal strength. The satellite transponder operates in the  $K_a$  band where multi-Mbps services are offered both for downstream and upstream Internet traffic.

### C. GSM Base Station

A picocell GSM Base Station (BS) is installed in every REDComm node. The BS operates in the 900MHz GSM band, which offers good propagation characteristics and is supported by the majority of the GSM mobile phones. The GSM BS supports voice and text services, and it is equipped with an Ethernet interface for direct IP connectivity, control and management. It supports both full rate and enhanced full rate voice coding, as well as adaptive multi-rate to increase capacity to 14 concurrent calls.

The specific BS covers a relatively small radius area and has lower capacity compared with a typical GSM infrastructure, but can be essential in case of absence or overload of the commercial mobile networks. In order to control the utilization two distinct classes are defined: the registered users, i.e. the rescuers, that have full access to the GSM services, and the unregistered ones, i.e. the general public, which can only dial the emergency telephone numbers, i.e. 112.

### D. ISDN Primary Rate Interface

An ISDN Primary Rate Interface (PRI) PCIe card is used to give the ability to communicate with the public telephone network, as well as to connect to any large Private Branch eXchange (PBX). This interface can support up to 30 digital voice channels for interoperability with non-IP systems and may be used as a gateway between various voice services of the REDComm node and any fixed telephone network. All voice services and the respective signaling and routing are handled by the open-source multi-protocol telephony platform FreeSWITCH [13].

### E. VHF/UHF Transceiver

In each REDComm node a VHF/UHF transceiver module is installed. This transceiver is capable of 50 Watt output power and covers the frequency bands of 118 to 524 MHz and 800 to 1300 MHz. It is based on a dual transceiver architecture allowing it to simultaneously receive and transmit signals. This way it can be used as a VHF/UHF repeater or as a VHF/UHF transceiver to be part of an ERA MANET.

Moreover, its audio input and output are connected through a custom interface to the node's workstation, which can route the sound and control the transceiver, presenting it as a VoIP device. Therefore, it can be used as an ISDN/GSM/VoIP to PTT gateway. This way voice calls from fixed and mobile users and VoIP sessions can be redirected to and from an ERA MANET.

### F. 802.11n Access Points

Three sector antennas, covering  $120^\circ$  each forming unidirectional  $360^\circ$  coverage, connected to three 802.11n Access Points (APs) equip each REDComm node. Each antenna has 13 dBi of gain and dual linear (Horizontal and Vertical) polarization. The APs are exploiting the Multiple Input Multiple Output (MIMO) technology to provide increased capacity and spectral efficiency combined with improved link reliability.

Thus the REDComm node can be used as a high performance, high capacity Wi-Fi hotspot. This functionality can be used by every 802.11-enabled device such as smart phones, tablets, laptops etc. as an alternative communication path for civilians that seek for assistance in an ECS.

The Wi-Fi together with the GSM base station can very valuable in ECS as victims can use widely spread consumer devices to communicate to the suitable ERAs and/or RTs especially in the case that fixed communication infrastructures have failed [14].

### G. FM Radio Transmitter

A typical FM transmitter is installed to a REDComm node in order to be able to provide broadcasting services for civilian information, as FM radio is a ubiquitous public address device.

### H. Video Camera

Each REDComm node has a high definition IP camera that can be used to provide live video streaming from the disaster area. The camera is motorized and can be panned and tilted remotely providing a very useful tool for live remote surveillance.

### I. Telescopic Mast

To increase wireless coverage and long distance performance all antennas are installed on top of a telescopic mast. The mast can be extended up to the height of 9.5 meters. It is operated by air pressure provided by a compressor, allowing it to extend and retract fast and easily by the manipulation of a pneumatic valve.

Nine different antennas (three for 802.11n, two for the GSM BS, three for the backbone network and one for the VHF/UHF transceiver) are placed on a special designed plateau attached to the top of the mast. To increase the mast's resistance to wind loads there is the option to attach four steel guy cables between the mast and the bottom trailer structure.

### J. Hybrid electric power source

A Hybrid electric Power Source (HPS) supplies the required electric power of a REDComm node. The architecture of the HPS is shown in Fig. 2. HPS consists of

three power sources: an electric petrol generator, three solar panels with a solar charge controller and a wind turbine with a charge controller. Solar and wind charge controllers are connected directly to a battery bank of 12V/500Ah capacity. A 1300 VA inverter is used to produce the required by many appliances 220 V AC output. The inverter also monitors the charge state of the battery bank and can provide up to 70 A of charge current. The petrol generator is rated 4500 VA and has an electric starter that can be combined with the inverter to activate it automatically if necessary. The total power rating of the solar panels is 255 W whereas the wind generator is rated at 400 W.

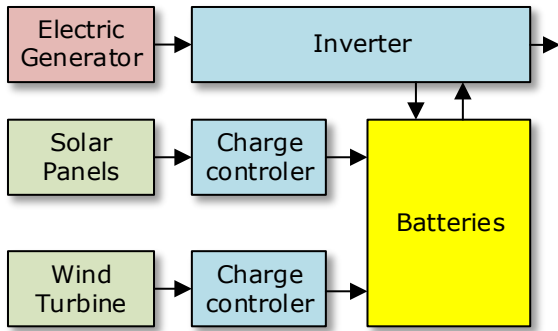

Fig. 2. Telescopic Hybrid electric power source architecture

#### IV. OPERATION SCENARIO

The REDComm node is can be rapidly deployed in case of ECS at or near the disaster scene to provide communication services. Multiple deployed nodes are able to form a mesh backbone network using the SDR based interfaces. Each REDComm node can operate independently and may route the network traffic accordingly to reach the desired destinations.

In case of an emergency, different RTs from different ERAs arrive at the scene. The typical PTT service that the RTs incorporate has severe limitations and requires the active human interaction in order to have interoperability between different ERA. The REDComm node can join any analog VHF/UHF-based voice network and act as router/gateway for the used PTT service. It has the capability to use its VHF/UHF radio transceiver as a typical VoIP client, taking advantage of the modern digital voice communication technologies. This way interoperability between different ERAs is achieved. In addition, coverage range can be extended by the relay of the PTT voice messages, using the IP backbone of the REDComm nodes.

Civilians can have access to the ERA in ECS to report emergency and/or seek for assistance. The added value of the REDComm node usage is that civilians can use their common personal devices, i.e. mobile phone, laptop, to do so. Through the GSM service a victim can access the emergency communication network formed by the REDComm node, using its GSM phone (112 emergency calls are supported) or using any wireless IP-enabled device (laptop, tablet, smartphone, etc.). Supported interoperability between heterogeneous technologies can allow a victim using his mobile phone to have direct contact, even with a PTT device if necessary.

As disaster mitigation is evolved, the involved RTs become part of a centrally coordinated plan. ERA headquarters can remotely contact RTs through VoIP services and VoIP to PTT gateway functionality of REDComm nodes allowing for robust and efficient coordination. Moreover, multimedia services, such as live video streaming from the disaster area, can be a valuable tool for the disaster mitigation planning.

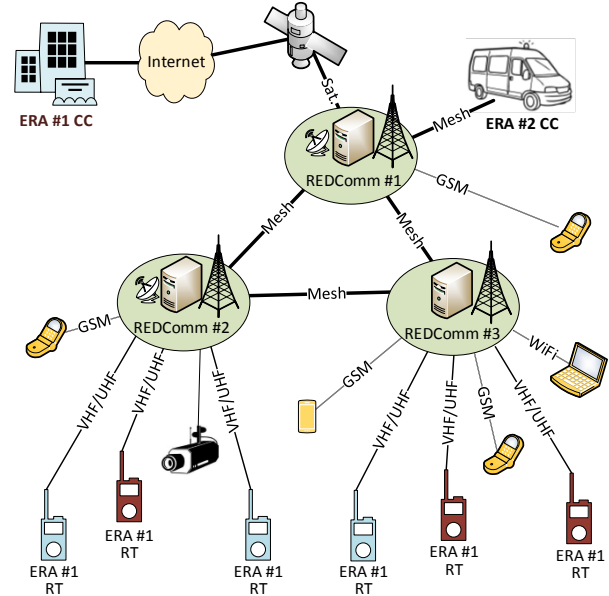

Fig. 3. Usage scenario for the REDComm nodes.

Fig.3 presents a typical example of the network topology of such a usage scenario. In this example two different ERA are participating in an ECS using their RTs. Three REDComm nodes have been deployed near the disaster area and interconnected by their SDR-based wireless backbone network. REDComm node #1 is also connected with the ERA #2 CC which could be a mobile command CC in a van near the disaster area. REDComm #1 node is also connected to the Internet through satellite link allowing ERA #1 CC to be a part of the emergency communication network. Each RT member remains in connection with its PTT network as long as he is within range of any REDComm node. For example, transmissions from ERA#1 RT member are relayed form both REDComm #2 and REDComm #3 nodes. Nevertheless, if required these transmissions can be relayed to ERA #2 RTs as well. Each node can also forward PTT voice transmission by VoIP technology to the ERAs coordination center and vice versa. This way a logical ERA voice network is established regardless of the geographic position of its members. Moreover, the traffic of the different logical networks can be routed to each other.

Victims may use GSM or Wi-Fi technology to communicate with emergency responders and ERAs. Regardless of each REDComm node's GSM cell coverage, appropriate call forwarding is implemented through PBX functionality to reach the desired destination, through the wireless backbone. It has to be noted that GSM access can

also be used by RTs and ERAs (by registering the individual SIM cards) as an alternative communication channel supporting call prioritization

## V. CONCLUSIONS

In the case of an emergency and crisis situations communication plays an important role in disaster mitigation. In such cases, existing communication infrastructures are possible to be unserviceable or have poor Quality of Service. On the other hand, as different emergency response authorities are involved in a disaster, there is the problem of interoperability between the communication technologies they use.

Eight rapid emergency deployment mobile communication nodes are being built by the Telecommunication and Networks Laboratory at the Institute of Computer Science of the Foundation for Research and Technology-Hellas, in the contest of the European project REDComm. These nodes are designed to support various types of services such as press to talk voice communication, GSM telephony with 112 emergency number support, Wi-Fi access with internet support, VoIP telephony, multimedia content sharing etc. in the case of an emergency and crisis situation.

To support the various types of services these nodes are equipped with multiple communication technologies. In addition, each node is energy independent from external power sources as it is powered by a hybrid power source using renewable and chemical combustion energy. It is intergraded in a trailer base providing mobility. Thus, it can be easily towed and deployed in the case of an emergency and support communications services in a 24/7 basis. Moreover, it utilizes an 802.11a wireless mesh network based on software-defined radios that are used as a backbone that is operating in the television white spaces frequency band. Using a cognitive access principle this backbone network take advantage of the lower path loss of the television bands to provide increased coverage range.

The developed nodes can support interoperability as they act as a gateway of the various implemented communication technologies providing capabilities of direct communication between all emergency response authorities. In addition direct communication between rescue teams and victims can be supported based on commercial widespread devices as mobile phones and Internet enabled devices.

In the near future when all eight nodes will be fully ready, performance evaluation trials will be performed. The main goal of the tests will be the evaluation and improvement of the multiple software components and the fine-tuning of the complete, integrated system. Additionally, along with the four Greek emergency response authorities that participate in the REDComm project, drills like [15] will be performed in order to evaluate the effects of REDComm nodes to emergency response, and to train the associated personnel to efficiently

use the REDComm nodes. The goal is to obtain a high degree of readiness for the case of a real emergency.

## ACKNOWLEDGMENT

REDComm nodes are constructed for the REDComm: Rapid Emergency Deployment mobile Communication Infrastructure (REDComm) project with the financial support of the Prevention, Preparedness and Consequence Management of Terrorism and other Security-related Risks Programme. European Commission - Directorate-General Home Affairs.

## REFERENCES

- [1] "Communications Broke Down on 9/11." Online available at: <http://www.firehouse.com/news/10519316/report-communications-broke-down-on-9-11, 2004>.
- [2] "The 9/11 commission report" Online available at: [http://news.bbc.co.uk/nol/shared/bsp/hi/pdfs/22\\_07\\_04911Report.pdf](http://news.bbc.co.uk/nol/shared/bsp/hi/pdfs/22_07_04911Report.pdf).
- [3] L. Comfort, T. Haase, "Communication, coherence, and collective action: The impact of Hurricane Katrina on communications infrastructure.", Public Works Management and Policy, 2006.
- [4] G. Vasilakis, G. Perantinos, I. Askoxylakis, N. Mechin, V. Spitadakis, A. Traganitis, "Business opportunities and considerations on wireless mesh networks", IEEE International Symposium on a World of Wireless, Mobile and Multimedia Networks & Workshops.
- [5] REDComm: Rapid Emergency Deployment mobile Communication Infrastructure, <http://www.redcomm-project.eu/>.
- [6] A. Fragkiadakis, I. Askoxylakis, E. Tragos and C. Verikoukis, "Ubiquitous robust communications for emergency response using multi-operator heterogeneous networks", EURASIP Journal on Wireless Communications and Networking, 2011.
- [7] "ARRL Amateur Radio Education & Technology Program, Repeater and Remote Operation", Online available at: [http://www.arrl.org/files/file/LabHandbook/RLH\\_Unit\\_6.pdf](http://www.arrl.org/files/file/LabHandbook/RLH_Unit_6.pdf).
- [8] "GNU radio, the free & open-source software radio ecosystem", Online available at: <http://gnuradio.org/redmine/projects/gnuradio/wiki>.
- [9] S. Kawade, M. Nekovee, "Can Cognitive Radio Access to TV White Spaces Support Future Home Networks?", in proc. of IEEE Dynamic Spectrum Access Networks (DySpan), 2010.
- [10] M. Delakis, K. Mathioudakis, N. Petroulakis, V. A. Siris, "Experiences and Investigations with Heraklion MESH: An experimental Metropolitan Multi-Radio Mesh Network", proc. of In Proc. of Int'l Conference on Testbeds and Research Infrastructures for the Development of Networks & Communities (TRIDENTCOM), 2008.
- [11] V. Siris, I. Askoxylakis, Marco Conti, Raffaele Bruno, "Enhanced, ubiquitous and dependable broadband access using MESH networks", ERCIM News, 2008.
- [12] V. Angelakis, A. Capone, A. Fragkiadakis, S. Napoli, S. Papadakis, G. Perantinos, V. Spitadakis, E. Tragos, D. Yuan. "Experience from testbeds and management platforms towards mesh networking with heterogeneous wireless access", IEEE International Symposium and Workshops on a World of Wireless, Mobile and Multimedia Networks (WoWMoM), 2013.
- [13] FreeSWITCH, a scalable open source cross-platform telephony platform designed to route and interconnect popular communication protocols using audio, video, text or any other form of media, On line available at: <http://www.freeswitch.org>.
- [14] A. Miaoudakis, N. Petroulakis, D. Kastanis and I. Askoxylakis, "Communications in Emergency and Crisis Situations", Proceedings of the 16th International Conference on Human-Computer Interaction, 2014.
- [15] "Earthquake followed by Tsunami in the Mediterranean Sea". On line available at: <http://84.205.229.30/poseidon/>, 2011.